

### 3 mm Square SMT Trimmer Potentiometers (Cermet, Open Frame Type)

Type: **EVM3Y**  
**EVM3S**  
**EVM3R**



3Y



3S



3R

#### ■ Features

- Automatic adjustment type (EVM3Y)
- Both sides adjust type (EVM3S)
- Back side adjust type and low-profile 0.9 mm (1.0 mm max.) EVM3R
- High reliability realized by cermet element
- Excellent mountability
- Conforms to JIS C5260-1:1999

#### ■ Recommended Applications

- Audio/visual, office, and communication equipment
- General electronic equipment

#### ■ Explanation of Part Numbers

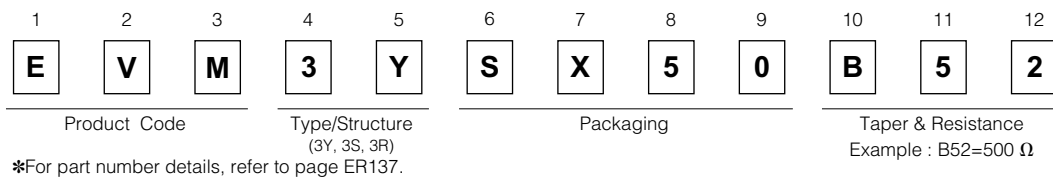

#### ■ Specifications

Total Resistance Value Resistance Tolerance	EVM3Y 3S : 100 Ω to 1 MΩ / EVM3R : 500 Ω to 1 MΩ ±25 %
Power Rating Maximum Operating Voltage	0.15 W 50 V
Rotation Torque	EVM3Y, 3S : 2 to 20 mN·m / EVM3R : 1 to 20 mN·m
Temperature Coefficient of Resistance	±250 × 10 <sup>-6</sup> /°C

#### ■ Minimum Quantity/Packing Unit

Part Number	Taping		
	Quantity per reel	Packaging quantity	Dia. of reel (mm)
EVM3Y EVM3S EVM3R	2000	10000	φ178

The standard packaging methods for a reel is φ178.  
Please contact us, if you would like different packaging methods. (Bulk, Reel of φ330, Reel of φ380)

■ Dimensions in mm (not to scale)

- 3-terminal, for Automatic Trimming Adjustment/Low-profile ..... EVM3Y

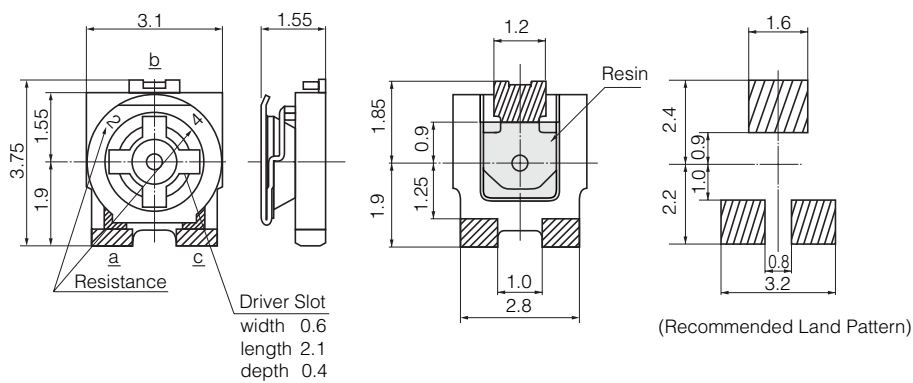
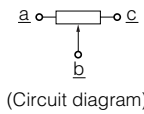
<p><b>No. 1</b></p> 	 <p style="text-align: center;">Driver Slot width 0.6 length 2.1 depth 0.4</p> <p style="text-align: center;">Mass (Weight) : 42 mg/pc.</p> <div style="text-align: center;">  <p>(Circuit diagram)</p> </div>
---	---

- 3-terminal, Both Sides Adjust ..... EVM3S

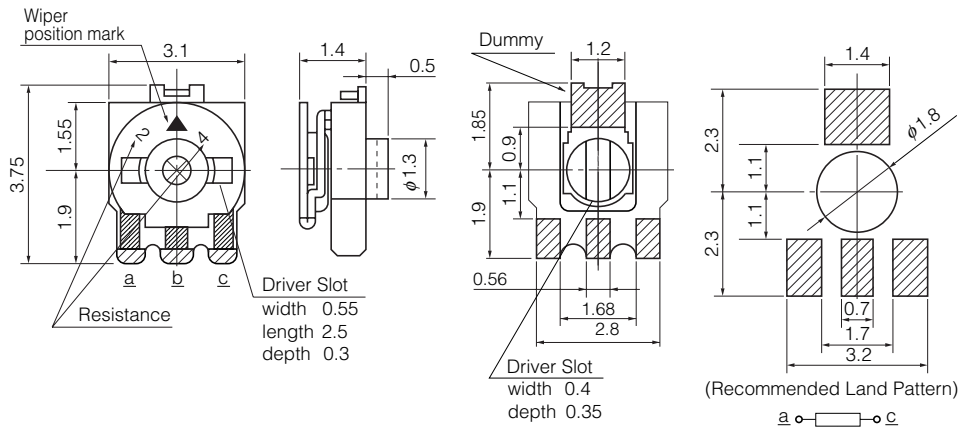
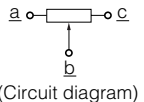
<p><b>No. 2</b></p> 	 <p style="text-align: center;">Driver Slot width 0.55 length 2.5 depth 0.3</p> <p style="text-align: center;">Mass (Weight) : 45 mg/pc.</p> <div style="text-align: center;">  <p>(Circuit diagram)</p> </div>
---	---

- 3-terminal, Back Side Adjust ..... EVM3R

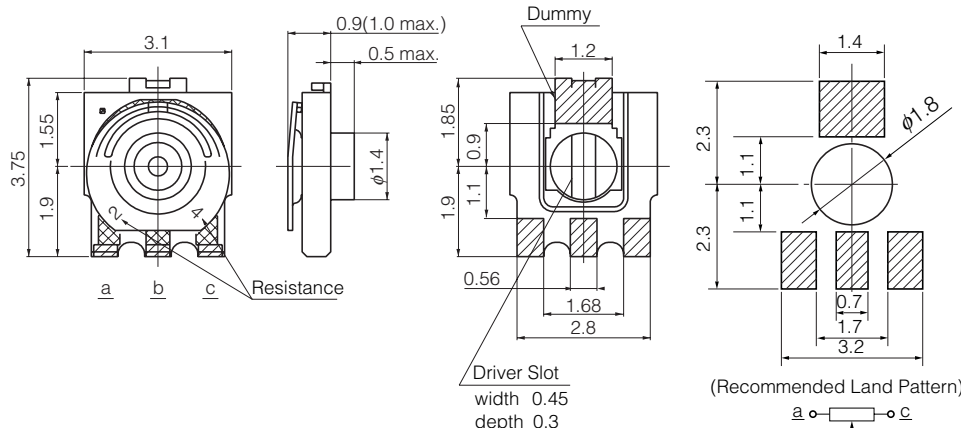
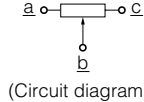
<p><b>No. 3</b></p> 	 <p style="text-align: center;">Driver Slot width 0.45 depth 0.3</p> <p style="text-align: center;">Mass (Weight) : 32 mg/pc.</p> <div style="text-align: center;">  <p>(Circuit diagram)</p> </div>
---	---

### ■ Explanation of Part Numbers

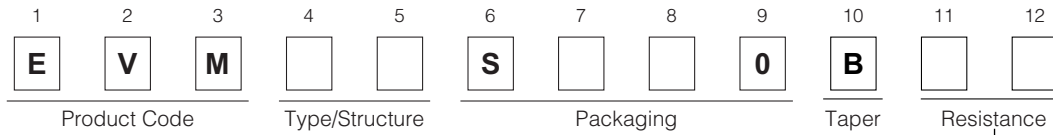

6th	7th	Packaging
S	X	Carrier tape (7th: Direction of insertion. Refer to Packaging Specifications)
	W	

\* The standard of direction of insertion is a direction X.  
EVM2T/2N type be only direction X.

8th	Quantity	Type
3	1000	EVM1D, EVM1E, EVM1U
5	2000	EVM3Y, EVM3S, EVM3R, EVM3V
8	3000	EVM2T, EVM2N, EVM2W, EVM3W

Classification	Type	Symbol(1th to 5th)
Cermet	2 mm Open	EVM2T, EVM2N, EVM2W (low-profile)
	3 mm Open	EVM3Y, EVM3S EVM3R, EVM3W(low-profile) EVM3V(with rotation stopper)
	4 mm Open	EVM1D, EVM1E EVM1U

Symbol	Resistance	EVM2T EVM2N EVM2W EVM3Y EVM3S EVM3W EVM3V EVM1D EVM1E EVM1U	EVM3R
12	100 Ω	○	—
C2	150 Ω	○	—
22	200 Ω	○	—
E2	220 Ω	○	—
32	300 Ω	○	—
Y2	330 Ω	○	—
Q2	470 Ω	○	—
52	500 Ω	○	○
S2	680 Ω	○	○
13	1 kΩ	○	○
C3	1.5 kΩ	○	○
23	2 kΩ	○	○
E3	2.2 kΩ	○	○
33	3 kΩ	○	○
Y3	3.3 kΩ	○	○
Q3	4.7 kΩ	○	○
53	5 kΩ	○	○
S3	6.8 kΩ	○	○
14	10 kΩ	○	○
C4	15 kΩ	○	○
24	20 kΩ	○	○
E4	22 kΩ	○	○
34	30 kΩ	○	○
Y4	33 kΩ	○	○
Q4	47 kΩ	○	○
54	50 kΩ	○	○
S4	68 kΩ	○	○
15	100 kΩ	○	○
C5	150 kΩ	○	○
25	200 kΩ	○	○
E5	220 kΩ	○	○
35	300 kΩ	○	○
Y5	330 kΩ	○	○
Q5	470 kΩ	○	○
55	500 kΩ	○	○
S5	680 kΩ	○	○
16	1 MΩ	○	○

